

ISI - FTW

STAND-BY SINGLE PHASE AC SINE WAVE, LOW CAPACITY, WALL MOUNTED UNINTERRUPTIBLE CENTRAL SYSTEM

The Inverter Systems, Inc. ISI-FTW provides a high efficiency single phase "stand-by" central AC emergency power system ideally suited for H.I.D., fluorescent and incandescent emergency lighting applications or other auxiliary loads that require a "fast transfer, no-break" voltage regulated and line conditioned power supply.

The ISI-FTW demonstrates exceptional 98% operating efficiency by means of the fast "no-break" transfer circuit, providing considerable running cost savings over typical double conversion UPS systems. Available in a wide range of voltages and four different capacities, the ISI-FTW is designed to provide up to 90 minutes of standby emergency power in accordance with the requirements of U.L. 924.



OPERATION

The inverter is normally off and the commercial AC power continuously supplies the critical load. The input converter (bi-directional transformer) derives power from the commercial AC power source and supplies to the inverter while simultaneously providing floating charge to the batteries.

Upon failure of the commercial AC power the inverter instantaneously, with a maximum of a 2-millisecond break, switches its power supply from the input converter to the battery system. There shall be no loss of power to the critical load upon failure or restoration of the utility source.

An automatic low voltage cutoff circuit disengages the inverter system at the useful end of the battery capacity preventing deep discharge battery damage. Upon restoration of the utility supply the system automatically returns to the normal "standby" mode and restores the battery to full charge.

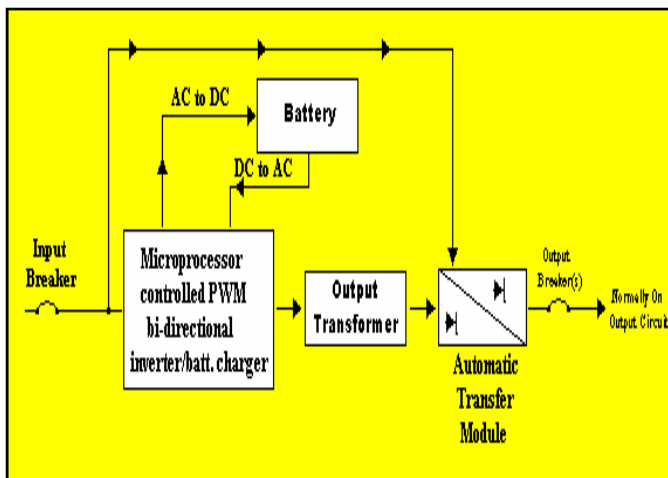

All specifications subject to change without notice.

STANDARD FEATURES:

- PWM/MOSFET Inverter Technology for high efficiency and low THD
- UL 924 listed and meets or exceeds the requirements of OSHA for emergency lighting and power. NFPA70, NFPA101, NFPA110, UBC, and SBCCI and New York City approved
- 98% efficient in standby mode means no fan for cooling
- Compatible with HID, fluorescent, incandescent, and electronic low voltage lighting
- Maintenance-free, sealed lead calcium valve regulated lead acid batteries
- Field upgradeable from 500VA to 2000VA by additional battery modules
- Protection circuit breakers are battery, Input and Output
- Front panel interface: Microprocessor controlled, 2x20 character display with touch pad controls
- Programmable setpoints are password-controlled with user and service levels
- Standard Alarms: Output, High Temp, Near Low Battery, Inverter, Load Reduction, Low Voltage, Charger, Overload, High Voltage, Low Battery, Overload Shutdown
- Digital metering indicates: input voltage, output voltage, current output, battery voltage, system days, date, inverter minutes, ambient temperature, battery current, inverter watts, VA output
- Diagnostic Features: User programmable with password protection for alarms and diagnostics, Self testing and diagnostic with event, test and alarm logs; Standard logs: alarm log (75), event log (75), test log (50)
- Small footprint, both inverter and battery unit each measure 26"W x 10"H x 10"D
- Floor or wall-mounted
- 16AWG (.059") steel construction with powder coat surface
- Modular design allows separation of inverter and battery modules
- Electrical knockouts for easy contractor connection and installation
- Circuit breaker and fuse access panel for easy routine maintenance

ISI-FTW Model Capacity VA	Efficiency @ full load	90 min. Average Battery current	Inverter Cabinet Dimensions (inches)			Battery Cabinet Dimensions (inches)			# Batt. Cabinets Required	*Current Input (amps)	*Current Output (amps)	Total system shipping weight (lbs.)
			W (A)	H (B)	D (C)	W (D)	H (E)	D (F)				
ISI-FTW-500	98%	13.5 ADC	26	10	10	26	10	10	1	5.2 / 1.8	4.16 / 1.8	206
ISI-FTW-1000	98%	26.5 ADC	26	10	10	26	10	10	2	10.5 / 3.61	8.33 / 3.61	335
ISI-FTW-1500	98%	40 ADC	26	10	10	26	10	10	3	15.62 / 5.42	12.5 / 5.41	464
ISI-FTW-2000	98%	52 ADC	26	10	10	26	10	10	4	20.8 / 7.22	16.66 / 7.22	592

*Current input reflects system at maximum charge current plus maximum load current

SPECIFICATIONS:

- The emergency lighting inverter system shall be a stand-by no-break system suitable for sustaining and operating H.I.D., fluorescent and incandescent lamps in the event of a power outage for a minimum 90 minutes duration at the rated load and be listed and labeled to U.L. 924.
- The entire system shall be of a modular construction with removable electronic modules for ease of installation and maintenance. Cabinets shall be constructed of code gauge steel with removable key locked hinged doors finished in an acid resistant enamel with a modified vinyl undercoat.
- The inverter shall be a standby UPS. PWM inverter type utilizing MOSFET technology with 2mS transfer time.
- The AC input voltage shall be (120 or 277V single phase two wire plus ground).
- The output voltage shall be provided as a) 120 or 277V single phase, two wire **normally on**, or b) 120 or 277V single phase, two wire or mixed 120V @(specify) VA, 277V @(specify) VA **normally off**. The output frequency shall be 60HZ ± 0.05HZ for all loads.
- The system shall reliably handle from .5 leading to .5 lagging power factor. The output voltage regulation shall be ±3% or better from 0% to 100% of rated load. The system's output shall be capable of 115% overload indefinitely, 125% for five minutes. Harmonic distortion <10% total or 3% any single harmonic.
- The battery charger, in the standard configuration shall convert AC voltage to DC voltage. With commercial power present, the inverter power transformer is powered and the bidirectional MOSFET recharges the batteries. Once the batteries have received full recharge, a constant trickle charge maintains batteries at maximum level. Recharge time is 24 hours maximum at nominal AC input voltage. The AC ripple current of the DC output meets the battery manufacturer specification, ensuring maximum life.
- The system's batteries shall be of the (sealed maintenance free lead acid) type.
- Options: Refer to Option Selection Chart for descriptions and nomenclature. Popular options are: Start-up Service, Output Circuit Breakers, Remote Meter Panel, Output Trip Alarms
- The system shall be an Inverter Systems model No. _____ as manufactured for and warranted by Inverter Systems, Inc. (for copy of detailed specification format - consult factory)

ORDERING GUIDE:

When ordering an ISI-FTW from Inverter Systems, Inc., use:

ISI-FTW - 500 - 277 - 277 - C(4) - SB - OPTIONS
 1 2 3 4 5 6 7

- | | |
|-----------------------------------|--|
| 1. Model Series | ISI-FTW |
| 2. Volt Amp (VA) Rating | 500 to 2000 |
| | Select required capacity in volt Amps from model tables above |
| 3. Input Voltage | |
| | 120V 2 wire plus ground 120 |
| | 277V 2 wire plus ground 277 |
| | Other voltages (specify) () |
| 4. Output Voltage | |
| | 120V 2 wire plus ground 120 |
| | 277V 2 wire plus ground 277 |
| | Other voltages (specify) () |
| 5. Output Circuit Breakers | |
| | Specify number of output circuit Breakers (maximum 2 per system) C () |
| 6. Battery Type | |
| | Maintenance free sealed lead acid SB |
| 7. Options | |
| | Select requirements from Options Guide, Popular options are: |
| | Start-up Service SUS |
| | Output Trip Alarm OTA |
| | Summary Dry Contacts (Form "C") DCS |
| | Remote Meter Panel RMP |

WARRANTY:

Electronics Assembly

Inverter Systems, Inc. warrants the ISI-FTW electronics assembly (except batteries) against defects in material and workmanship for a period of one year from date of shipment. Inverter Systems, Inc. will either repair or replace any properly installed ISI-FWT system which fails under normal operating conditions provided that it is returned to the factory, transportation prepaid, and our inspection determines it to be defective under the terms of this warranty. When buying Start-up Service, customer gets an additional year of parts and labor with warranty.

The warranty covers only equipment other than batteries manufactured by Inverter Systems, Inc. and does not extend to transportation, installation or replacement charges, nor does it apply to any other equipment of another manufacturer used in conjunction with ISI equipment. No other warranty expressed or implied exists beyond that included in this statement.

Battery Warranty

Sealed lead calcium batteries carry a 1 year full, 9 year pro-rated limited warranty.

Important note: Battery warranty is limited to certain environmental, operational and installation limitations (refer to detailed Battery Warranty Terms and Conditions).

