

# ISI - MINI

## STANDARD TRANSFER CENTRAL INVERTER AND DC BACKUP POWER SUPPLY COMBINATION UNIT

The Inverter Systems, Inc. MINI provides a high efficiency single phase power system combination for fluorescent, incandescent and low voltage emergency lighting applications.

Available in a 120 or 277 voltage and two different capacities, the ISI-MINI is designed to provide up to 90 minutes of standby emergency power in accordance with the requirements of U.L. 924.

### OPERATION

The inverter is normally off and the commercial AC power continuously supplies the critical load. The input converter (bi-directional transformer) derives power from the commercial AC power source and supplies to the inverter while simultaneously providing floating charge to the batteries.

Upon failure of the commercial AC power the inverter instantaneously, with a maximum of a 6-millisecond break, switches its power supply from the input converter to the battery system.

An automatic low voltage cutoff circuit disengages the inverter system at the useful end of the battery capacity preventing deep discharge battery damage. Upon restoration of the utility supply the system automatically returns to the normal "standby" mode and restores the battery to full charge.

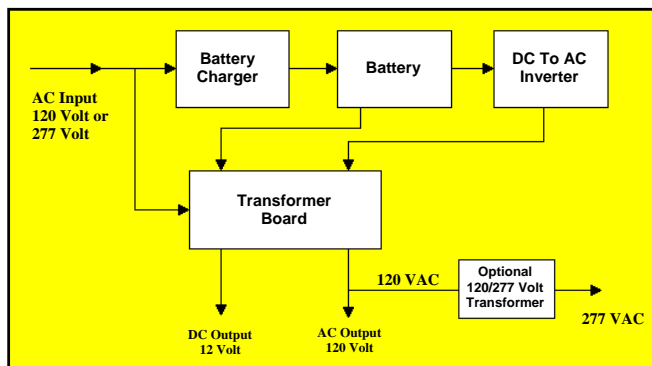
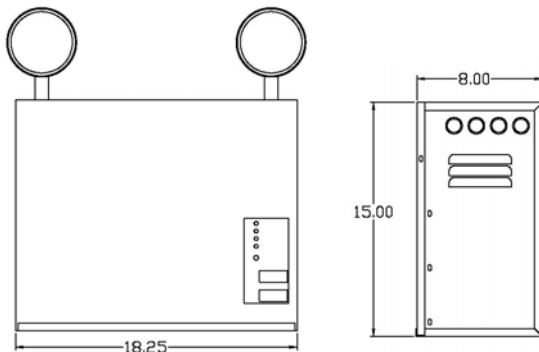

### STANDARD FEATURES:

- Pure sine wave AC Power
- 12 or 24 Volt DC Power
- 300 or 400 Watts DC Power
- 300 or 400 Watts AC Power
- 300 or 400 Watts AC and DC Power combined
- Three outputs: Two DC and One AC
- Battery Voltmeter and Ammeter
- ETL Listed to U.L. 924 Standards
- High efficiency
- Compatible with fluorescent, incandescent, and electronic low voltage lighting
- Maintenance-free, sealed lead calcium, lead acid batteries
- Compact, wall-mounting measuring 18" W x 15" H x 8" D
- 16AWG (.059") steel construction with powder coat surface
- Electrical knockouts for easy contractor connection and installation
- DC output fuse indication
- Push button test switch and LED indicators
- Short or open on any one output does not effect the other two outputs
- One year warranty, two year optional

All specifications subject to change without notice.

| ISI-MINI<br>Model Capacity<br>VA | Volts AC | Efficiency<br>@ full load | 90 min.<br>Average<br>Battery<br>current | Inverter Cabinet<br>Dimensions (inches) |    |   | *Current<br>Input<br>(amps) | *Current<br>Output<br>(amps) | Total approx.<br>system shipping<br>weight<br>(lbs.) |
|----------------------------------|----------|---------------------------|--|---|----|---|-----------------------------|------------------------------|--|
|                                  |          |                           |  | W                                       | H  | D |                             |                              |  |
| ISI-MINI-300                     | 120      | 87%                       | 28.7 ADC                                 | 18                                      | 15 | 8 | 3.0                         | 2.5                          | 75   |
| ISI-MINI-300                     | 277      | 78%                       | 31.9 ADC                                 | 18                                      | 15 | 8 | 1.3                         | 1.1                          | 75   |
| ISI-MINI-400                     | 120      | 86%                       | 38.8 ADC                                 | 18                                      | 15 | 8 | 3.8                         | 3.3                          | 115  |
| ISI-MINI-400                     | 277      | 77%                       | 43.1 ADC                                 | 18                                      | 15 | 8 | 1.7                         | 1.4                          | 115  |

\*Current input reflects system at maximum charge current plus maximum load current.

## SPECIFICATIONS:

- The emergency lighting inverter system shall be a standard transfer (6ms) high efficiency off-line system suitable for sustaining and operating fluorescent and incandescent lamps in the event of a power outage for a minimum 90 minutes duration at the rated load and be listed and labeled to U.L. 924.
- The entire system shall be of a modular construction with removable electronic modules for ease of installation and maintenance. Cabinets shall be constructed of code gauge steel finished in an acid resistant enamel with a modified vinyl under-coat.
- The inverter shall be a standby system.
- The AC input voltage shall be (120V or 277V single phase two wire plus ground).
- The output voltage shall be any combination of AC and DC output voltage options providing the AC input and output voltage are the same. The output frequency shall be 60/50HZ  $\pm$ 1HZ for all loads.
- The system shall reliably handle from .5 leading to .5 lagging power factor. The output voltage regulation shall be  $\pm$ 5% or better from 0% to 100% of rated load. The system's output shall be capable of 115% overload indefinitely, 125% for five minutes. Harmonic distortion <10% total or 3% any single harmonic.
- The battery charger, in the standard configuration shall convert AC voltage to DC voltage. With commercial power present, the inverter power transformer is powered and the bidirectional MOSFET recharges the batteries. Once the batteries have received full recharge, a constant trickle charge maintains batteries at maximum level. Recharge time is 24 hours maximum at nominal AC input voltage. The AC ripple current of the DC output meets the battery manufacturer specification, ensuring maximum life.
- The system's batteries shall be of the (sealed maintenance free lead acid) type.
- Options: Refer to Option Selection Chart for descriptions and nomenclature.
- The system shall be an Inverter Systems model No. \_\_\_\_\_ as manufactured for and warranted by Inverter Systems, Inc. (for copy of detailed specification format - consult factory)

## ORDERING GUIDE:

When ordering an ISI-MINI from Inverter Systems, Inc., use:

ISI-MINI - 300 - 277 - 277 - 12 - S - SB - OPTIONS  
1 2 3 4 5 6 7 8

|   |  |
|---|--|
| 1. <b>Model Series</b>  | ISI-MINI                                     |
| 2. <b>Volt Amp (VA) Rating</b><br>Select required capacity in volt  | 300 or 400                                   |
| 3. <b>Input Voltage</b><br>120 Volt<br>277 Volt   | 120<br>277                                   |
| 4. <b>AC Output Voltage</b><br>120 Volt<br>277 Volt   | 120<br>277                                   |
| 5. <b>DC Output Voltage</b><br>12 Volt<br>24 Volt   | 12<br>24                                     |
| 6. <b>Mounting</b><br>Mounting shelf (standard)   | S  |
| 7. <b>Battery Type</b><br>Maintenance free sealed lead acid   | SB   |
| 8. <b>Options</b><br>One Lamp Head<br>Two Lamp Heads<br>Gray Housing<br>Black Housing<br>Remote Test Switch<br>Time Delay (120 Volt)<br>Time Delay (277 Volt) | 1H<br>2H<br>G<br>B<br>RT<br>TD-120<br>TD-277 |



## WARRANTY:

### Electronics Assembly

Inverter Systems, Inc. warrants the ISI-MINI electronics assembly (except batteries) against defects in material and workmanship for a period of one year from date of shipment. Inverter Systems, Inc. will either repair or replace any properly installed ISI-MINI system which fails under normal operating conditions provided that it is returned to the factory, transportation prepaid, and our inspection determines it to be defective under the terms of this warranty.

The warranty covers only equipment other than batteries manufactured by Inverter Systems, Inc. and does not extend to transportation, installation or replacement charges, nor does it apply to any other equipment of another manufacturer used in conjunction with ISI equipment. No other warranty expressed or implied exists beyond that included in this statement.

### Battery Warranty

Sealed lead calcium batteries carry a 1 year full, 7 year pro-rated limited warranty.

Important note: Battery warranty is limited to certain environmental, operational and installation limitations.