

EGRESSOR-PLUS

EMERGENCY LIGHT

Rugged construction for the most demanding industrial applications. The ISI Egressor-Plus (EGR-P) series offers 150, 200, 250, 300 and 400 lamp watts of emergency power in 12 or 24 volts. The EGR-P series has been designed with state of the art electronics including our battery lockout circuit, which allows the battery to be connected to the circuit even when AC power is not available. Lamp heads are factory installed on the unit as just another example of ISI's ease on installation.

FEATURES

- Sealed maintenance free lead batteries.
- Battery lockout circuit.
- LVD - low voltage disconnect.
- Choice of lamp heads.
- Temperature compensation and brownout circuit.
- High charge and AC ready LED.
- Dual voltage transformer (120/277VAC)
- Rugged 20-gauge steel housing.
- Units in white, black, or industrial gray powder finished coating.
- 3 year warranty on unit and battery, 5 years additional pro rata on battery.
- Short circuit resistance circuit.



SERIES	COLOR	VOLTAGE	WATTAGE	LAMP HEADS	OPTIONS
EGR-P EGRESSOR PLUS SERIES	2 WHITE	12	125 150	SEE BELOW	SEE BLEOW
	3 BLACK		200 300		
	4 GRAY	24	400		

LAMPHEADS

00	No Heads	08	6V, 18W SB
01	6V, 5.4W H.I.T	09	6V, 25W SB (METAL HEADS)
02	6V, 7.2W H.I.T.	10	12V, 9W H.I.T.
03	6V, 8W SBH	11	12V, 8W SBH
04	6V, 9W H.I.T	12	12V, 12W SB
05	6V, 9W SB	13	12V, 12W SBH
06	6V, 12W SB	14	12V, 18W SB
07	6V, 12W SBH	15	12V, 25W SB (METAL HEADS)

*** SB = SEALED BEAM
*** SBH = SEALED BEAM HALOGEN

OPTIONS

SD	Self Diagnostics
TP	Tamper Proof
VM	Voltmeter
AM	Ammeter
TD	Time Delay
NC	Ni-Cad Battery

*For more available options, please contact factory.

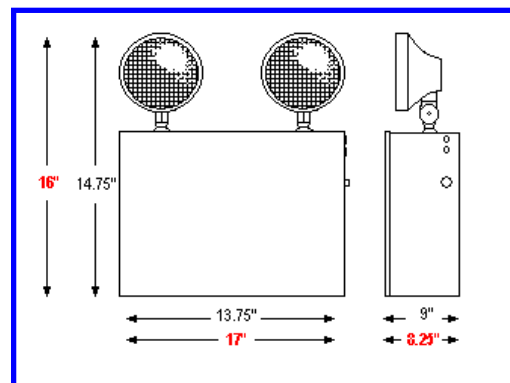

Consult factory for dimensions for your application.

AGENCY APPROVAL

Meets the illumination requirement of NFPA Life Safety Code 101, 5-10.2.2. Certified and tested to UL924. ETL listed.

