

# ISI - IPS3

## STANDARD TRANSFER CENTRAL INVERTER

The Inverter Systems, Inc. IPS3 central inverters represent the state-of-the-art in central inverter technology. On-board micro-processors control all system functions and provide the user with information concerning operation of critical system functions. The inverter design utilizes the latest PWM/IGBT technology for efficiency and reliability.

Systems are floor mounted, convection cooled and mounted in heavy gauge sheet metal cabinets requiring front access only. Key-locked doors are supplied for added security and safety. Each cabinet contains knockouts for inter-wiring with BX, Romex, or conduit. Systems 5.0kVA and below are self-contained while larger systems require external, stackable battery cabinets to house the batteries which supply 90 minutes of emergency run time.

### OPERATION

The AC utility shall power the load through an electro-mechanical switch with a 10000 AIC rating. A Bi-directional transformer shall also power the battery charger, which in turn charge the batteries. Instantaneously after a utility power failure or utility brownout condition, the solid state driven transfer switch will disconnect the AC utility from the load, start the inverter and connect the load to this energy storage transformer. The maximum interruption to the load for this transition shall be 50 millisecond maximum. The inverter will power the load with a low distortion sine wave form, simulating the AC utility. After the AC utility returns, the transfer switch shall reconnect the AC utility to the load with a 50 millisecond maximum interruption and the battery charger shall automatically recharge the batteries. Complete load protection from overload or over voltage shall be accomplished via the on-board microprocessor. This method provides maximum load protection from any IPS3 failure mode.

This inverter shall be designed with a microprocessor that control IGBT transistors and generates a sinusoidal pulse width modulation (PWM) output. All magnetic (transformers, chokes, etc.) used within the inverter shall be constructed from UL class H materials. The battery charger shall include a full wave bridge rectifier. It shall be of solid state construction and provide two rates of charge. This charger shall provide a constant voltage, current limited charge. Recharge time shall be 24 hours maximum.



### STANDARD FEATURES:

- Available in standard capacities from 1500 VA to 16.7 kVA
- Modular design provides electronic assemblies mounted.
- 98% high-efficiency off-line operation
- State of the art IGBT technology.
- Compatible with fluorescent, incandescent, and electronic low voltage lighting
- COMPATIBLE WITH L.E.D. APPLICATIONS**
- Short-circuit protected.
- Standard front panel instrumentation includes, indicators: battery charging, battery power, AC line present, system ready; metering: input voltage, output voltage, battery voltage, battery current, AC output current; and system test switch.
- Alarms: output fault, inverter fault, charger fault, high temperature, battery voltage, early warning
- Maintenance free sealed lead calcium batteries are standard.
- Special three phase combination systems available upon request.
- Total harmonic distortion 6% or 3% any one occurrence or less for linear loads at unity power factor.
- 125% overload capability for 5 minutes in emergency mode.
- Handles loads with power factors from .5 lag to .5 lead.
- Output frequency regulation  $\pm 1\%$  in emergency mode.
- Precision multi-rate battery charger.
- 24 hour recharge for extended battery life.
- Heavy gauge steel cabinets with filtered air louvers, key locks and removable hinged front opening doors for ease of access and maintenance.
- System cooling by a fan and natural convection means.
- Engineered for standard 90 minute emergency operation, extended run times available (consult factory).
- Suitable for extreme temperature conditions from  $0^{\circ}$  to  $+40^{\circ}$  C (continuous operation at high or low ambient temperatures may affect battery capacity and life, see battery warranty sheet for details).
- New York City approved.
- U.L. 924 listed.

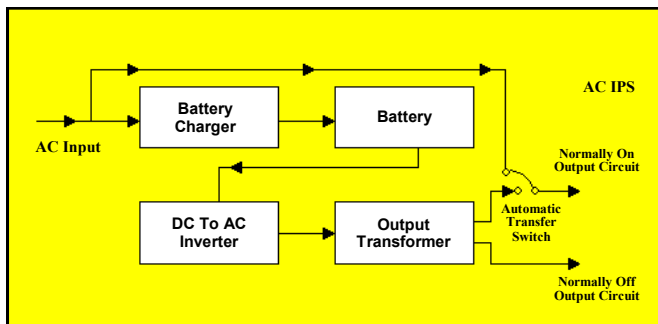

All specifications subject to change without notice.

[www.invertersystemsinc.com](http://www.invertersystemsinc.com)

329 Otter Street, Bristol, PA 19007 • Tele: (215) 788-8870 • Fax: (215) 788-8873

ISI

ISI-IPS3 Model Capacity VA	Efficiency @ full load	Heat Loss BTU's	Inverter Cabinet Dimensions (inches)			Weight (lbs.)	Battery Cabinet Dimensions (inches)			# Batt. Cabinets Required	Weight of add'l Batt. Cabinets (lbs.)	Total system shipping weight (lbs.)
			W (A)	H (B)	D (C)		W (D)	H (E)	D (F)			
ISI-IPS3-1500	98%	75	30	47	25	250				--		546
ISI-IPS3-2250	98%	100	30	47	25	265				--		709
ISI-IPS3-3000	98%	160	30	47	25	295				--		887
ISI-IPS3-3750	98%	200	30	47	25	305				--		1045
ISI-IPS3-5000	98%	245	30	47	25	315				--		1203
ISI-IPS3-6000	98%	300	30	47	25	350	30	47	25	1	210	1670
ISI-IPS3-8000	98%	400	30	47	25	375	30	47	25	2	232	2087
ISI-IPS3-10,000	98%	500	30	47	25	435	30	47	25	2	420	2631
ISI-IPS3-12,500	98%	660	30	47	25	465	30	47	25	2	420	3105
ISI-IPS3-16,700	98%	840	30	47	25	530	30	47	25	3	464	3954

## SPECIFICATIONS:

- The emergency lighting inverter system shall be a standard transfer (50ms) high efficiency off-line system suitable for sustaining and operating fluorescent, incandescent lamps, and LED's in the event of a power outage for a minimum 90 minutes duration at the rated load and be listed and labeled to U.L. 924.
- The entire system shall be of a modular construction with removable electronic modules for ease of installation and maintenance. Cabinets shall be constructed of code gauge steel with removable key locked hinged doors finished in an acid resistant enamel with a modified vinyl undercoat.
- The inverter shall be solid state design with transistor power drive circuit for precision switching and maximum reliability with regulated Ferro resonant output transformer.
- The AC input voltage shall be (120 or 277V single phase two wire plus ground).
- The output voltage shall be provided as a) 120 or 277V single phase, two wire, or mixed 120V @(specify) VA, 277V @(specify) VA **normally on**, or b) 120 or 277V single phase two wire, or mixed 120V @(specify) VA, 277V @(specify) VA **normally off**. The output frequency shall be 60HZ ±1HZ for all loads.
- The system shall reliably handle from .5 leading to .5 lagging power factor. The output voltage regulation shall be ±4%. The system's output shall be capable of 130% overload for 5 minutes. Harmonic distortion 3% total.
- The battery charger is microprocessor controlled that continuously monitors and maintains the systems batteries and has a low voltage disconnect for long battery life. The charger shall fully recharge the batteries within the requirements of U.L. 924 specifications.
- Self-Protective Features: Output short circuit protection with fail safe start-up, and reverse input polarity protection.
- The system's batteries shall be of the sealed maintenance free lead acid type.
- Options: Refer to Option Selection Chart for descriptions and nomenclature. Popular options are: Start-up Service, Output Circuit Breakers and Variable Time Delay.

The system shall be an Inverter Systems model No. \_\_\_\_\_ as manufactured and warranted by Inverter Systems, Inc. (for copy of detailed specification format - consult factory).

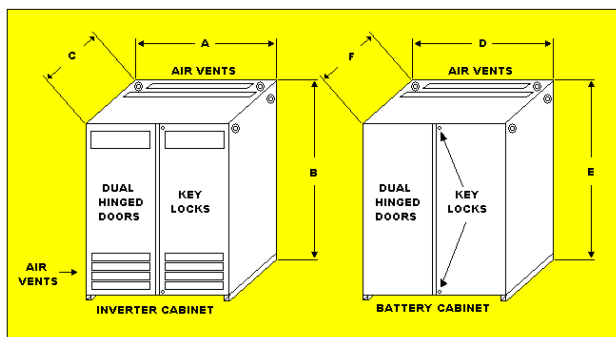

## ORDERING GUIDE:

When ordering an ISI-IPS3 inverter from Inverter Systems, Inc. use:

ISI-IPS3 -  $\frac{6K}{1}$  -  $\frac{277}{2}$  -  $\frac{277}{3}$  -  $\frac{277}{4}$  -  $\frac{C(4)}{5}$  -  $\frac{SB}{6}$  -  $\frac{OPTIONS}{7}$

- Model Series** ISI-IPS3
- Volt Amp (VA) Rating** 1500 to 16,700  
Select required capacity in volt amps from model tables above
- Input Voltage**  
120V 2 wire plus ground 120  
277V 2 wire plus ground 277  
Other voltages (specify) ( )
- Output Voltage**  
120V 2 wire plus ground 120  
277V 2 wire plus ground 277  
Other voltages (specify) ( )
- Output Circuit Breakers**  
Specify number of output circuit breakers C ( )  
(maximum 10 per system, unmonitored)
- Battery Type** SB  
Maintenance free sealed lead acid
- Options** SUS TD  
Start-up service  
Time Delay

## WARRANTY:

### Electronics Assembly

Inverter Systems, Inc. warrants the ISI-IPS3 electronics assembly (except batteries) against defects in material and workmanship for a period of one year from date of shipment. Inverter Systems, Inc. will either repair or replace any properly installed ISI-IPS3 system which fails under normal operating conditions provided that it is returned to the factory, transportation prepaid, and our inspection determines it to be defective under the terms of this warranty.

The warranty covers only equipment other than batteries manufactured by Inverter Systems, Inc. and does not extend to transportation, installation or replacement charges, nor does it apply to any other equipment of another manufacturer used in conjunction with ISI equipment. No other warranty expressed or implied exists beyond that included in this statement.

\*TWO YEAR WARRANTY WHEN START-UP SERVICE IS PURCHASED

### Battery Warranty

Sealed lead calcium batteries carry a 1 year full, 10 year pro-rated limited warranty. Important note: Battery warranty is limited to certain environmental, operational and installation limitations (refer to detailed Battery Warranty Terms and Conditions).