

MINI-EGRESSOR EMERGENCY LIGHT

The ISI Mini-Egressor (M-EGR) offers both 6 volt and 12 volt systems that provide up to 54 lamp watts of emergency power. Series M-EGR offers state-of-the-art electronics, economy, and ease of installation as found in all ISI products. Lamps are factory installed, and our battery lockout circuit allows the battery to be connected even when AC power is not available. This eliminates returning to the job site to connect the battery. Series M-EGR housings are gray, white, or black powder coated 20 gauge steel. Lamp heads are high impact flame retardant plastic.

FEATURES

- 12, 18, 27 watts (6 volt) in smaller housing (2.5" deep)
- 27, 36, 54 watts (12 volt) in 4.5" deep housing
- Sealed maintenance free lead batteries.
- Battery lockout circuit
- LVD - low voltage disconnect.
- Temperature compensation and brownout circuit.
- High charge and AC ready LED.
- Dual voltage transformer (120/277VAC)
- Rugged 20-gauge Steel housing.
- 3 year warranty on unit and battery, 5 years additional pro rata on battery.
- Short circuit resistance circuit.



SERIES	COLOR	VOLTAGE	WATTAGE	LAMP HEADS	OPTIONS
M-EGR MINI-EGRESSOR SERIES	2 WHITE	6 12	12 18	SEE BELOW	SEE BELOW
	3 BLACK		27 36		
	4 GRAY		54		

LAMPHEADS

00	No Heads	08	6V, 18W SB
01	6V, 5.4W H.I.T	09	6V, 25W SB (METAL HEADS)
02	6V, 7.2W H.I.T.	10	12V, 9W H.I.T.
03	6V, 8W SBH	11	12V, 8W SBH
04	6V, 9W H.I.T	12	12V, 12W SB
05	6V, 9W SB	13	12V, 12W SBH
06	6V, 12W SB	14	12V, 18W SB
07	6V, 12W SBH	15	12V, 25W SB (METAL HEADS)

*** SB = SEALED BEAM
*** SBH = SEALED BEAM HALOGEN

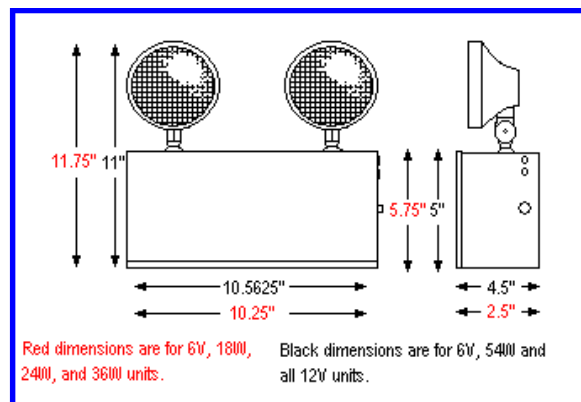

OPTIONS

SD	Self Diagnostics
TP	Tamper Proof
VM	Voltmeter
AM	Ammeter
TD	Time Delay
NC	Ni-Cad Battery

*For more available options, please contact factory.

AGENCY APPROVAL

Meets the illumination requirement of
NFPA Life Safety Code 101, 5-10.2.2.
Certified and tested to UL924. ETL listed.

